

60" X 30" - 8 1/2" Offset Drain Shower Pan

Specifications

- Model: Offset Drain Pan
- Pan Size: 60" x 30"
- Finish: Textured - Non Slip
- Side Wall: 30"
- Back Wall: 60"
- Drain Location: Center - Drain Measures:
15" from Backwall
8 1/2" from Side Walls
- Drain Openings: 3 1/4"
- Front Curb: Integral 3 1/2" High
- Integral Flange on Sides and Back
- Weight: 148.00 lbs.
- Material: Cultured Marble
- Our Product Comply with one or more of the following: IAPMO, ANZI, CSA & ASTM F462-79 Coefficient of Friction Test

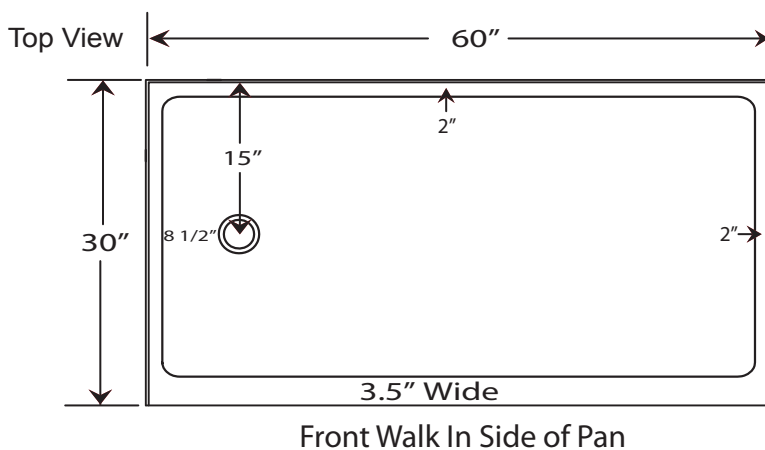

Standard Features

- Solid One Piece Construction
- Abrasion Resistant Gel Coat Surface
- Seamless
- Pre-leveled - Rest on Sub Floor
- Extremely Sanitary
- Water Proof and Leak Proof
- Bacteria Resistant
- Easy to Install
- Maintenance Free
- 10 Year Limited Warranty
- Made in the USA

Additional Accessory Options

- Shower Pan Protector

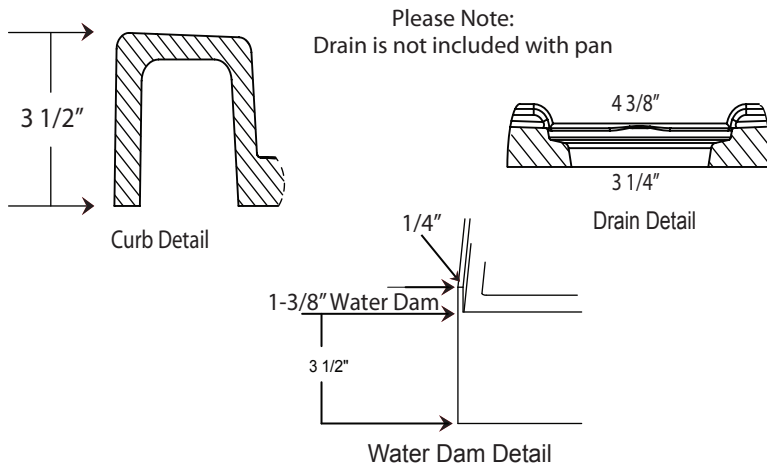

To review color options for this product please contact your Sales Representative or refer to our website at:

www.mplcompany.net/request-color